

self-locking glider

# Thera-Glide®

R, T & W Series (Wood & Oasis)



FOCUSED ON WHAT MATTERS

SPECIALTY  
HEALTHCARE



WOOD MODEL (W-2)



W-3 MODEL

INSTRUCTION MANUAL

[lpamedical.com](http://lpamedical.com)

2527 Dalton avenue, Quebec (Qc) G1P 3S6 CANADA  
T 418-681-1313 1-800-663-4863 F 418-681-4488

# A WORD OF THANKS

Congratulations and thank you for purchasing your chair from LPA Medical.

Since 1989, LPA Medical has been dedicated to designing and manufacturing chairs to meet the most demanding requirements of the healthcare community. Our products are designed with comfort and durability in mind for both long-term and short-term uses. We are proud to manufacture quality products that incorporate advanced features into an aesthetic design that helps maintain the user's dignity and well-being.

Please read this instruction manual carefully and consult it often to maximize the benefits of your LPA chair. If you have any questions after reading it, do not hesitate to contact your LPA representative, contact us directly through our website, or use our phone number, listed below.

We hope that you enjoy your LPA Medical chair and we thank you for your business.

Bryan Welch  
President

LPA Medical inc.  
2527 avenue Dalton,  
Quebec City, QC, Canada G1P 3S6

T: 418-681-1313  
F: 418-681-4488  
Toll free : 1-800-663-4863

info@lpamedical.com  
www.lpamedical.com

# TABLE OF CONTENT

A Word of Thanks.....	2
Replacement Parts Availability Policy.....	4
General Information.....	4
Definitions.....	4
Safety Measures.....	5
Applications.....	5
Inspection Before Use.....	6
Risk Prevention.....	6
Improper Uses.....	6
Cleaning.....	7
Maintenance.....	7
Operating Functions.....	7
Models and Options.....	8
Adjustment and Operating Instructions.....	9
Seat Height.....	9
Seat Depth.....	10
Backrest Angle.....	11
Contemporary Backrest.....	13
Locking the Chair.....	15
Additional Ergonomic Recommendations.....	16
Getting Up.....	16
Sitting Down.....	16
Options and Accessories.....	16
Terms & Conditions.....	17
General.....	17
Damage during Transportation.....	17
Returns.....	17
General Warranty.....	18
Our Commitment.....	18
Exclusions.....	1
Parts List.....	20
Serial Number Location.....	21
Exploded View.....	22

# REPLACEMENT PARTS AVAILABILITY POLICY

LPA Medical's replacement parts availability policy ensures parts for at least 10 years after the purchase of your LPA product, which makes it:

- An eco-friendly purchase. If anything breaks, you know that replacement parts will be available for a long time. Why throw your chair away when you can fix it?
- An economical purchase. You'll enjoy substantial savings due to your LPA chair's enhanced durability.

In addition, we are proud to provide one of the most comprehensive warranties on the market.

## GENERAL INFORMATION

This document is a guide for the use and maintenance of your LPA chair. It is important that anyone using the chair reads it in its entirety.

It is the responsibility of caregivers, including family or loved ones using this chair, to follow the instructions in this manual at all times and to ensure proper care and maintenance of the LPA chair.

**LPA Medical Inc.** accepts no responsibility for any breakage, incident, injury, damage or accident caused by improper use, failure to safely maintain the chair in good operating condition through any unauthorized modification of the chair, failure to follow instructions in this manual or any other use deemed abnormal.

LPA products are not designed to be pressure-washed or washed in automatic wheelchair washers.

LPA products are not designed to be used outdoors or to be used in the shower.

## DEFINITIONS

### **Self-locking glider chair**

A chair that can be used for rocking while being safe for seated/standing transfers because of its automatic locking mechanism and its stability.

### **Adjustments (height, depth, backrest angle)**

Functions to configure the chair to fit different body types.

### **Mechanism activation lever**

Function to switch the chair from rocking into a fixed position.

### **Patient or user**



The chair's end-user; the person receiving the care.

## SAFETY MEASURES

The assignment of the Thera-Glide® chair, its positioning adjustments and mobilization maneuvers must be performed by professionals who have received training for this purpose. Caregivers must have received adequate training by an LPA Medical representative or by a third party having received this training before using the chair. This instruction manual will be used as a reference for continuing education. It is strongly recommended to appoint a caregiver responsible for training and to maintain an up-to-date list of those who have received it. For patient safety, anyone who has not received the proper training should not be allowed to operate the chair.

## APPLICATIONS

The Thera-Glide® chair is designed for all users, for home care, whether long or short term. The chair's therapeutic effects are recognized for reducing anxiety, maintaining independence and for its safety features.

-  The Thera-Glide chair is not designed to be cleaned with a pressure washer or an industrial washing machine. Such practices can lead to component rust and void warranties. In addition, LPA chairs are not designed for outdoor use.
-  The Thera-Glide chair must be used with accessories specifically designed for it by **LPA Medical Inc.** It must be used in accordance with recognized health and safety practices.

## INSPECTION BEFORE USE

The chair can be shipped fully assembled or partially assembled. It must be inspected when unpackaged and you must notify your supplier if there is any damage or missing parts/accessories so that the situation is remedied before taking possession.

## RISK PREVENTION

The wide spectrum of use of the Thera-Glide® chair requires special attention for risk assessment and prevention. It acts as a preventive measure for autonomous users or those with a loss of autonomy. Adjustments to accommodate different body shapes must be made properly by a qualified person or supervised by this person. In cases where the patient is restless, in-chair behavior should be observed to assess the risks. In addition, the chair must not be placed within reach of guardrails, bed rails or fixed objects that could be gripped and cause a tip-over, or to avoid a possible pinch point. Note that for these cases the patient should always be under assistance and supervision. These measures are necessary for patient safety. Using a tray for restraint purposes is prohibited and can lead to situations of strangulation that may cause death. Only the use of approved and prescribed restraints is accepted.

**Note: Contact us for more information about installing positioning straps.**

## IMPROPER USES

- Handling the chair without proper training.
- Moving the chair without using the rear casters (if present).
- Use with a patient without professional referral.
- Making adjustments without supervision or prior training.
- Leaving an at-risk patient in an unsecured or unattended place.
- Moving the chair with the patient in it.
- Exceeding the permitted weight limit.

# CLEANING

Follow the selected covering manufacturer's recommendations for cleaning. Check with your supplier that the products you use are compatible.

- ✘ The chair should not be pressure-washed or placed inside a washing machine. These practices may cause the chair components to rust internally, as well as deteriorate the adjustment components, thus voiding the LPA chair warranty.

# MAINTENANCE

As long as the recommendations for use and cleaning are followed, the Thera-Glide chair does not require any preventive maintenance. Some parts will need to be replaced due to normal wear and tear over years of use.

# OPERATING FUNCTIONS

The main components for safe use of the Thera-Glide® chair are:

- A. Backrest cushion.
- B. Backrest mechanism.
- C. Locking system activation lever.
- D. Locking system cable.
- E. Self-locking cylinder.
- F. Anti-tip stabilizers.

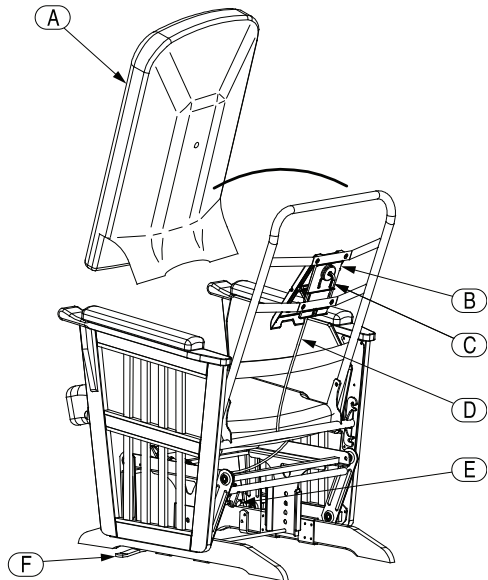

## MODELS AND OPTIONS

The Thera-Glide® chair is available in different models with options and accessories to provide better comfort.

Code	Description
R-C1*	Adjustable seat depth and backrest angle, 15" to 18" (38 to 46 cm) / 95 to 115 degrees
RA-01	Plastic table tray
RA-02	Activity tray with Lexan window
RA-03	Lateral tray straps
RA-03A	Wrap-around tray strap
RA-04	Rear wheel set for Thera-Glide® wood
RA-09	Side storage bag
RA-10	1" (2.5 cm) seat insert
RA-13	Seat wedge insert
RA-19	Universal perineal abductor kit with black fixing mat
RA-23	4" (10 cm) lateral trunk supports with backrest canvas
RA-24	6" (15 cm) lateral trunk supports with backrest canvas
RA-28-D	Option without undercarriage cover
RA-29	Option without backrest lever
RB-18	Neck rest
WOF-22	Fabric-covered ottoman with footrest
Z-C8	PRE-CURE® PRO cushion

\*Optional on 20", standard on 17" and 24" models.



# ADJUSTMENT AND OPERATING INSTRUCTIONS

## SEAT HEIGHT

1. Lay the chair on its side.
2. Using a  $\frac{5}{8}$ " wrench and an  $\frac{11}{16}$ " wrench, unscrew the hex nut on the inside of the leg support, then remove the washers and bolt. If the leg support seems stuck, apply a gentle twist to release it.

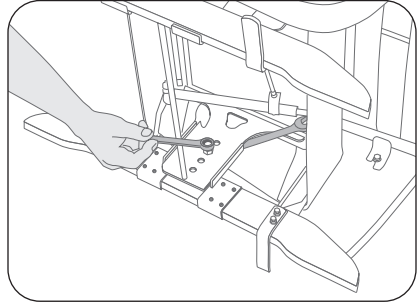

3. Place it at the desired height, and replace the bolt, washers and nut. Tighten firmly.

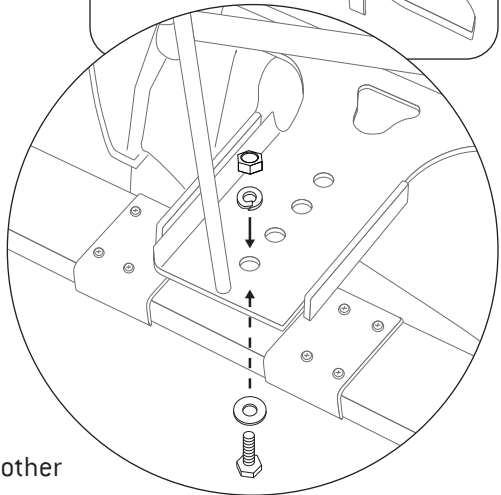
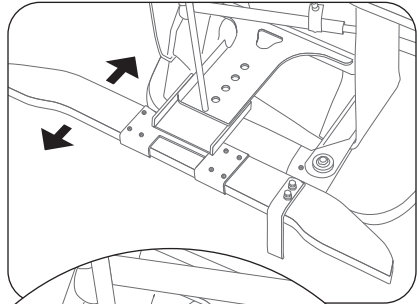

4. Repeat this operation on the other side of the chair.



Adjust the height (from 16" to 19") based on the length of the user's forearm. It is important that their hips, knees and ankles are at 90 degrees. The feet must be able to make good contact with the floor.

## SEAT DEPTH

1. Remove the backrest and seat cushions (see assembly instructions to do this).

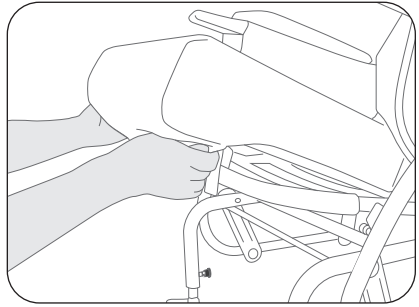

2. Using a 1/2" (13 mm) open-end wrench, loosen (DO NOT REMOVE) the 2 hex bolts on the slots located on each side of the back of the seat.

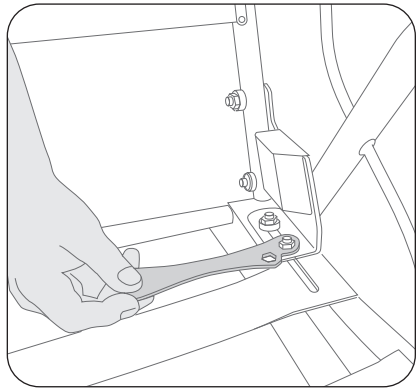

3. Adjust the depth as desired and tighten the bolts. Adjust the 2 sides to the same depth using the guide marks on the slots.

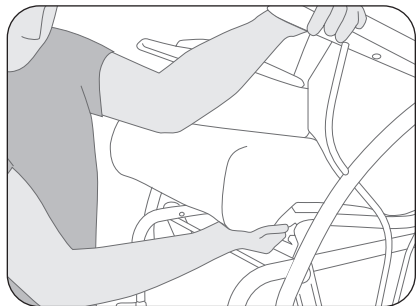

4. Reinstall the seat and back cushions.



The seat depth adjustment (from 15" to 18") is done according to the length of the user's leg. It is important that the back of the knee (called the popliteal fossa) has clearance. Adjust the depth of the seat so that you can pass a hand easily between the knee and the seat cushion. This adjustment will provide good seat and back contact with the backrest.

## BACKREST ANGLE

1. Remove the backrest and seat cushions (see assembly instructions to do this).
2. Remove the protective housings by loosening the screw with a Robertson #2 screwdriver.

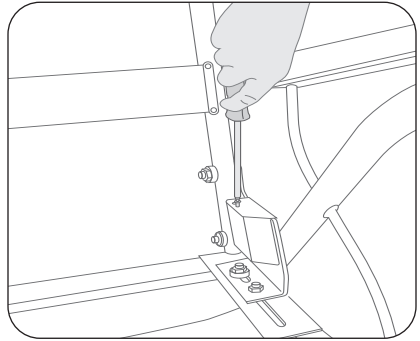

3. Using a  $\frac{9}{16}$ " (14mm) wrench, loosen the two cap nuts at the bottom of the backrest's tubular frame.

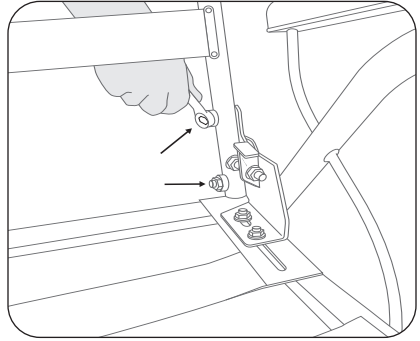

4. Move the bolts back to decrease the back angle, or forward to increase it. Make sure you have the same number of turns on each side.

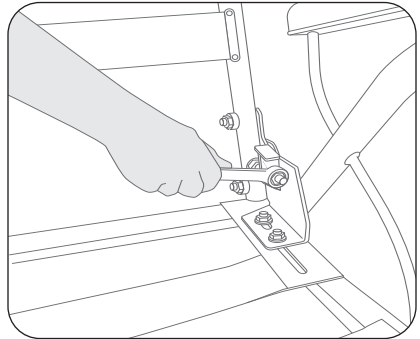

## BACKREST ANGLE (continued)

5. Make sure the frame is fully seated on the set bolts and tighten the cap nuts on the tubular frame.

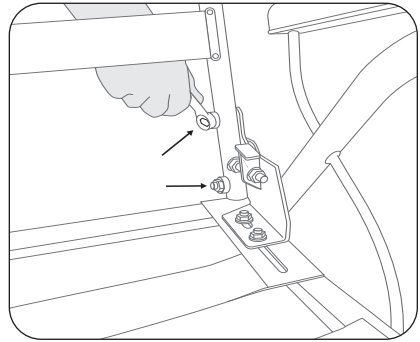

6. Replace the protective covers.

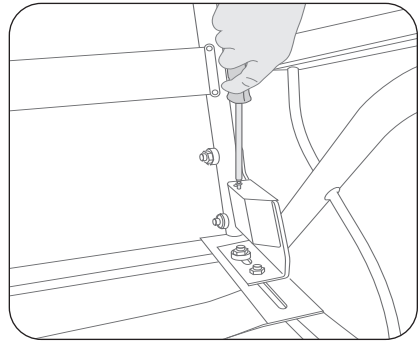

7. Reinstall the seat and backrest cushions.

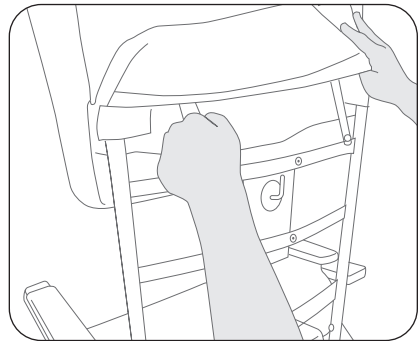

The backrest angle adjustment can vary from 95 to 115 degrees to accommodate the shape of a user's back. Adjust the backrest tilt for a comfortable position with the lower back supported as well as the head so that there is a good field of vision in front of you. This posture will make it easier to activate your chair's rocking mechanism.

## CONTEMPORARY BACKREST

These instructions apply to the **Contemporain (Contemporary)** backrest. If you have another kind of backrest cushion, go to the next section.

1. Pick up the cushion, head up. Make sure the inner straps dangle freely at the bottom of the backrest. The end of the straps should slightly extend beyond the bottom of the cushion.

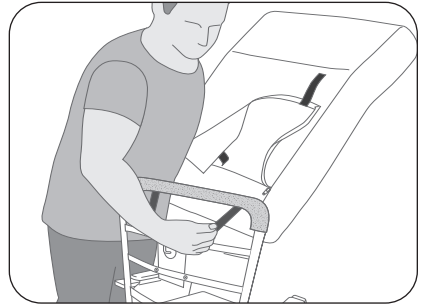

2. Begin slipping the bottom of the backrest cushion over the tubular backrest frame. Pass the straps behind the padded part of the top of the structure, then over the two slats of the cradle locking mechanism.

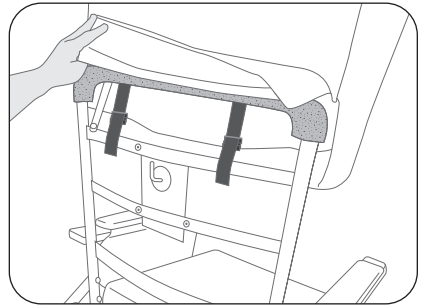

3. Continue to slip the cushion on the backrest by pulling on the straps and/or the bottom flap. Make sure to slide the mechanism activation lever through the hole in the backrest cover. If you encounter resistance, stop pulling in case the straps are not sliding correctly. Remove the cushion and start over.

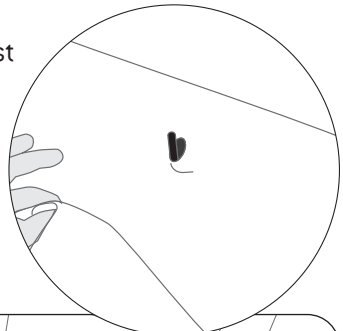

4. When the cushion is fully-lowered, run the straps under the lower slat of the tubular backrest structure.

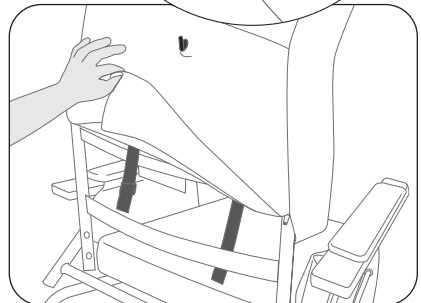

## CONTEMPORARY BACKREST (continued)

5. Pull one strap down, then fold it over the bottom slat and hook the plastic J-molding over the top of the slat. Repeat with the other strap.

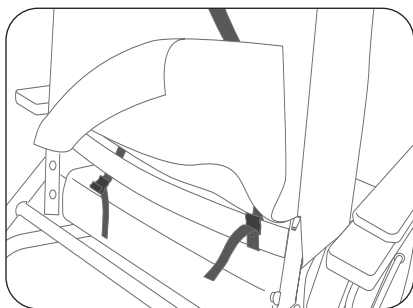

6. Close the zippers on each side.

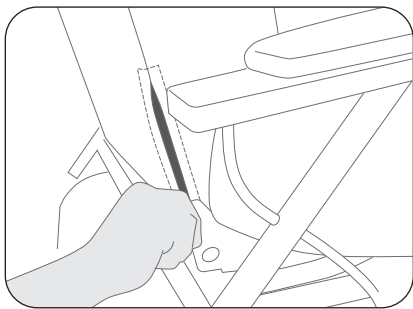

7. Insert the washer with instruction sticker over the mechanism activating lever, until it is affixed on the cushion.

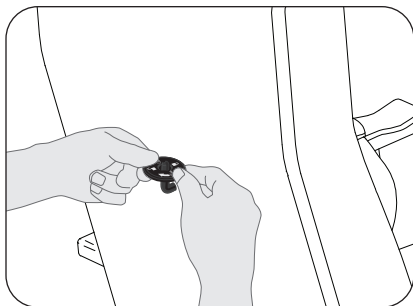

8. Thread the black elastic ring over the mechanism activating lever, and press it onto the washer to secure it in place.

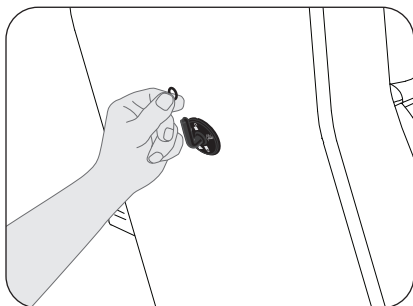

# LOCKING THE CHAIR

1. Turn the mechanism activation lever upward to activate the mechanism.

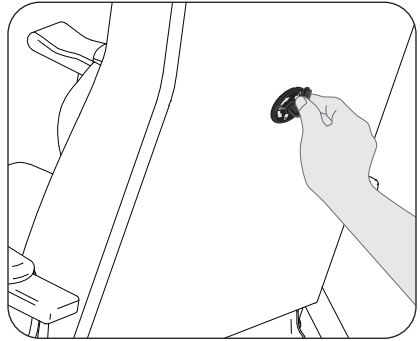

2. Turn the mechanism activation lever down to prevent rocking.

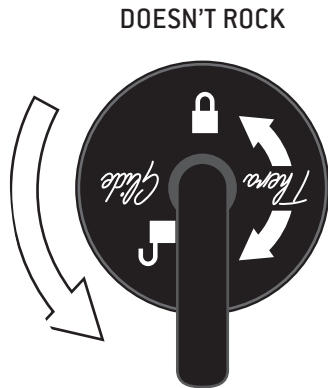
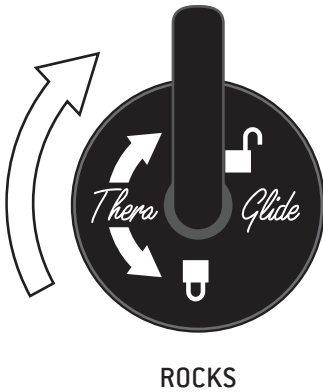
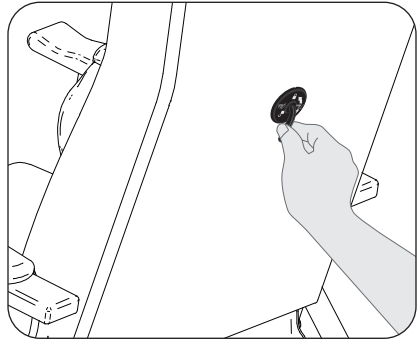

# ADDITIONAL ERGONOMIC RECOMMENDATIONS



## GETTING UP

To get up from the Thera-Glide® chair more easily (always do so in the presence of another person who has received training):

Slide your seat to the front of the chair

- Bring your feet under the seat
- Place your hands on the armrests
- Lean forward at core level while looking straight ahead.



## SITTING DOWN

To sit in the Thera-Glide® chair safely (always do so in the presence of another person who has received training):

- Position yourself in front of the chair and step back until the back of your knees touch the seat
- Bend your knees while placing your hands on the armrests
- Slide the seat into the back of the chair



## OPTIONS AND ACCESSORIES

There are a multitude of options and accessories available to customize your Thera-Glide® chair for your specific needs and/or if your condition changes in order to optimize your rocking experience. Don't hesitate to ask questions about the fit of your chair.



# TERMS & CONDITIONS

APPLICABLE TO PRODUCTS PURCHASED AS OF SEPTEMBER 1, 2018

## GENERAL

**LPA Medical inc.** reserves the right to modify without notice or obligation the design, specifications and prices of the equipment it manufactures. Shipping is charged at the current price at the time of delivery.

The minimum order requirement is \$25.

## DAMAGE DURING TRANSPORTATION

All goods damaged by transport must be immediately reported upon delivery, followed by a written claim within five (5) days. A copy of the claim must be sent to LPA. Any unreported damage during this period will void the **LPA Medical Inc.** warranty.

Additional costs of handling and/or using a platform when unloading may apply and are at the customer's expense.

## RETURNS

Merchandise to be returned must have prior written authorization from our Customer Service Department. All return requests must contain the following information:

- The reason(s) for the return.
- The LPA invoice number or delivery slip.
- The LPA model or part number.
- The number of items being returned.

Unauthorized returns will not be accepted. All authorized returns must be shipped pre-paid except where there has been an error in processing or a defect in materials or workmanship. In this case, contact **LPA Medical Inc.** for special instructions.

## GENERAL WARRANTY

The **LPA Medical Inc.** warranty covers manufacturing defects for the original owner/user, except for the exclusions below, for the periods below from the date of purchase:

Useful life\* for the metal structure of the chairs.

5 years on the wooden structures of self-locking rocking chairs

### **Thera-Glide® models W and T.**

3 years for the backrest mechanism of **Thera-Glide®** self-locking rocking chairs.

3 years on the padding of the chairs.

2 years for all other mechanisms, gas or mechanical locking cylinders, control cables, wheels, table trays.

1 year on all accessories purchased separately from chairs and replacement parts.

If a part is missing, contact our customer service with the following information:

1. Model, serial # and part #.
2. Purchase date and invoice number.
3. Description of the problem.

\* The useful lifespan of an LPA chair is estimated to be 10 years.

## OUR COMMITMENT

**LPA Medical inc.** agrees to provide replacement parts for a period of 10 years after the date of purchase of the product. **LPA Medical Inc.** reserves the right to provide replacement parts with a different design than that of the replaced part, at its sole discretion.

**LPA Medical Inc.'s** obligation is expressly limited to correcting the defect by adjusting, repairing or replacing the equipment, at LPA's sole discretion.

## **EXCLUSIONS**

- Normal wear and tear.
- Water or fire damage, including damage from pressure washers and automatic wheelchair washers.
- Rust and damaged covering.
- Unauthorized repair or modification or done with parts other than the original ones.
- Damage resulting from abnormal or abusive use.
- Damage caused by exposure to weather.

# PARTS LIST

Nº	[17"]	[20"]	[24"]	Description
1	RP-2117	RP-2017	RP-2217	Base and rocker set (incl. 2,3,4)
2	RP-2116	RP-2016	RP-2216	Base frame only
3	RP-2122	RP-2022	RP-2222	Front rocker
4	RP-2121	RP-2021	RP-2221	Rear rocker
5		RP-2018-DR		W series right side wooden leg and support with fitting
6		RP-2018-GA		W series left side wooden leg and support with fitting
7		RP-2015-DR		W-10 tubular metal leg, right
8		RP-2015-GA		W-10 tubular meta leg, left
9	N/D	RP-2030	N/D	Seat frame for fixed backrest
10	RP-2131	RP-2031	RP-2231	Seat frame for depth-adjustable backrest (option R-C1)
11		RP-1055-DR		R-C1 right adjustable backrest frame with cover
12		RP-1055-GA		R-C1 left adjustable backrest frame with cover
13	RP-0940	RP-1040	RP-4040	Backrest frame
14		RP-1060		Thera-Glide® backrest activation mechanism
15		RP-1080	RP-1080.24	Thera-Glide® cylinder stop with installation hardware
16		RP-50		Thera-Glide® hole cover washer
17		RP-20-DR *	RP-21-DR *	Mission right framing with fittings and reinforcement plates
18		RP-20-GA *	RP-21-GA *	Mission left framing with fittings and reinforcement plates
19		RP-3010-DR		Curved wooden armrest with mounting brackets, right
20		RP-3010-GA		Curved wooden armrest with mounting brackets, left
21		RP-01		Rear anti-tip and left or right wheel (unit)
22		RF-12 *		Right side wooden armrest wedge
23		RF-13 *		Left side wooden armrest wedge
24		RF-14 *		Right side wooden armrest
25		RF-15 *		Left side wooden armrest
26	RA-28-17 *	RA-28-20 *	RA-28-24 *	Thera-Glide® series W base cover
27		RY-40-DR *	RY-41-DR *	Right side W-10 armrest with mounting bracket
28		RY-40-GA *	RY-41-GA *	Left side W-10 armrest with mounting bracket
29		RY-45-DR *	RY-46-DR *	Right side W-30 armrest with stitching and mounting bracket
30		RY-45-GA *	RY-46-GA *	Left side W-30 armrest with stitching and mounting bracket
31	RY-51-17 *	RY-51-20 *	RY-51-24 *	W-10 seat cushion
32	RY-52-17 *	RY-52-20 *	RY-52-24 *	W-20 and W-30 seat cushion with stitching
33	RY-53-17 *	RY-53-20 *	RY-53-24 *	W-10 Contemporary seat cushion
34	RY-54-17 *	RY-54-20 *	RY-54-24 *	W-20 and W-30 Contemporary seat cushion with stitching
35	RY-64-17 *	RY-64-20 *	RY-64-24 *	Comfort plus backrest cushion
36	RY-67-17 *	RY-67-20 *	RY-67-24 *	Series W Classic backrest cushion
37		RY-68 *		W-20 armrest cushion, right
38		RY-69 *		W-20 armrest cushion, left
39		STP0101		Cable lock mechanism
40		WOF-22 *		Fixed wooden footstool

\* Always specify the color, width, fabric pattern and serial number of the Thera-Glide chair when ordering replacement parts. See page 21 for the location of the serial number. Replacement parts may have slight color differences from those of the original chair. LPA Medical cannot be held responsible for these differences.

## SERIAL NUMBER LOCATION

Each **LPA Medical Inc.** chair is identified by a serial number. Always provide your LPA chair's serial number when ordering replacement parts.

The serial number can be found on a label affixed on the right rear of the metal base structure.

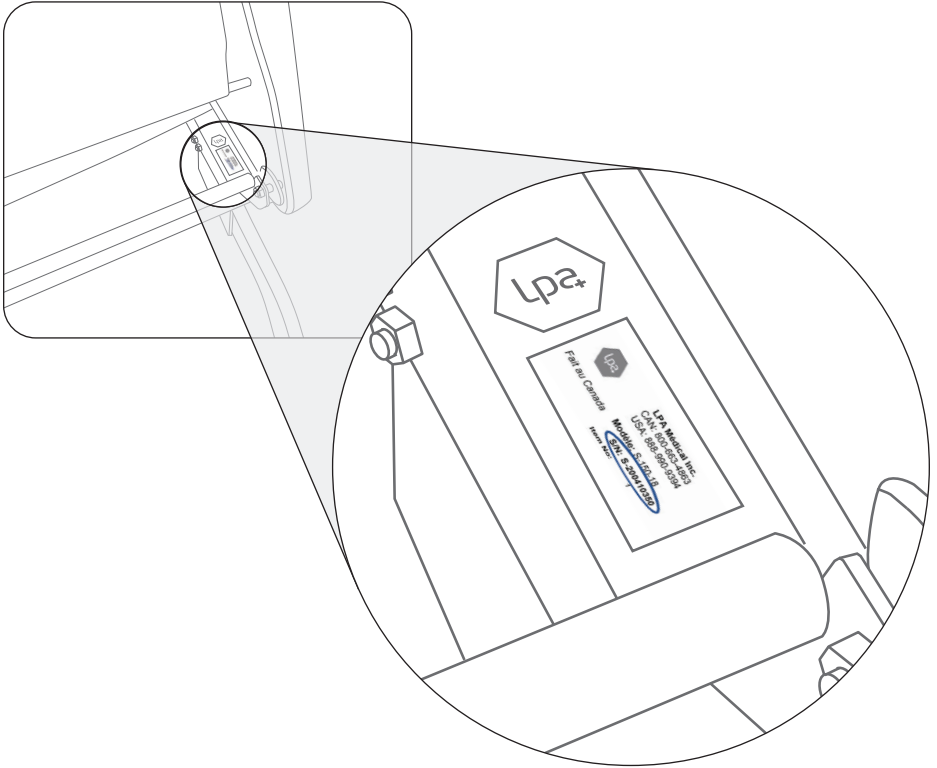

# VUE ÉCLATÉE EXPLODED VIEW

