

mobility chair
Evolution
S-250

FOCUSED ON WHAT MATTERS



SPECIALTY
HEALTHCARE



INSTRUCTION MANUAL

lpamedical.com

2527 Dalton avenue, Quebec (Qc) G1P 3S6 CANADA
T 418-681-1313 1-800-663-4863 F 418-681-4488

A WORD OF THANKS

Congratulations and thank you for purchasing your chair from LPA Medical.

Since 1989, LPA Medical has been dedicated to designing and manufacturing chairs to meet the most demanding requirements of the healthcare community. Our products are designed with comfort and durability in mind for both long-term and short-term uses. We are proud to manufacture quality products that incorporate advanced features into an aesthetic design that helps maintain the user's dignity and well-being.

Please read this instruction manual carefully and consult it often to maximize the benefits of your LPA chair. If you have any questions after reading it, do not hesitate to contact your LPA representative, contact us directly through our website, or use our phone number, listed below.

We hope that you enjoy your LPA Medical chair and we thank you for your business.

Bryan Welch
President

LPA Medical inc.
2527 avenue Dalton,
Quebec City, QC, Canada G1P 3S6

T: 418-681-1313
F: 418-681-4488
Toll free : 1-800-663-4863

info@lpamedical.com
www.lpamedical.com

TABLE OF CONTENT

A Word of Thanks.....	2
Replacement Parts Availability Policy.....	4
General Information.....	4
Definitions.....	5
Safety Measures.....	5
Applications.....	6
Inspection Before Use.....	6
Risk Prevention.....	7
Improper Uses.....	8
Cleaning.....	8
Maintenance.....	8
Operating Functions.....	9
Possible Adjustements.....	9
Adjustment and Operating Instructions.....	10
Seat/Floor Height.....	10
Seat Depth.....	11
Seat/Backrest Angle.....	12
Tilt-in-Space.....	14
Armrest Height.....	17
Lateral Supports – Optional.....	18
Using the Footrests – Optional.....	20
Serial Number Location.....	21
Options and Accessories.....	22
Additional Ergonomic Recommendations.....	23
Cervical Support.....	23
Positioning Strap.....	23
Footrests.....	23
Getting Up.....	23
Sitting Down.....	24
Moving Using the Hands and Feet.....	24
Options and Accessories.....	24
Terms & Conditions.....	25
General.....	25
Damage During Transportation.....	25
Returns.....	25
General Warranty.....	26
Our Commitment.....	26
Exclusions.....	26
Parts List.....	27
Exploded View.....	28

REPLACEMENT PARTS AVAILABILITY POLICY

LPA Medical's replacement parts availability policy ensures parts for at least 10 years after the purchase of your LPA product, which makes it:

- An eco-friendly purchase. If anything breaks, you know that replacement parts will be available for a long time. Why throw your chair away when you can fix it?
- An economical purchase. You'll enjoy substantial savings due to your LPA chair's enhanced durability.

In addition, we are proud to provide one of the most comprehensive warranties on the market.

GENERAL INFORMATION

This document is a guide for the use and maintenance of your LPA chair. It is important that anyone using the chair reads it in its entirety.

It is the responsibility of caregivers, including family or loved ones using this chair, to follow the instructions in this manual at all times and to ensure proper care and maintenance of the LPA chair.

LPA Medical Inc. accepts no responsibility for any breakage, incident, injury, damage or accident caused by improper use, failure to safely maintain the chair in good operating condition through any unauthorized modification of the chair, failure to follow instructions in this manual or any other use deemed abnormal.

LPA products are not designed to be pressure-washed or washed in automatic wheelchair washers.

LPA products are not designed to be used outdoors or to be used in the shower.

DEFINITIONS

Mobility chair

A chair designed to meet the comfort and mobility needs of people who are at risk of falls.

Tilt

A function enabling the seat and backrest to tilt together.

Adjustments

Functions to configure the chair to fit different body types.

Patient or user

The chair's end-user; the person receiving the care.

SAFETY MEASURES

Chair assignment, positioning adjustments and mobilization handling must be performed by professionals who have been trained for this purpose. The dynamic design of the chair requires a period of observation of the user's behavior in the chair. The care team must ensure that it does not pose a risk to their safety or that of others.

Before using the chair, caregivers must have received adequate training from an LPA Medical representative or a trained third party. This instruction manual will be used as a reference for continuing education.

It is strongly recommended to appoint a caregiver responsible for training and maintaining an up-to-date list of those who have received training. For the patient's safety, anyone who has not received adequate training should not be allowed to use the chair.

APPLICATIONS

The Evolution chair is designed primarily for long-term care or to be used at home for self-sufficiency and rehabilitation. It allows patients at risk of falls to move freely with their legs and arms while sitting in the chair, reducing anxiety and disruptive behaviors. The Evolution chair can be an excellent alternative to restraints. It is also used as a comfort chair to be mobilized by responders, even if the user does not move autonomously. The assignment and initial adjustments must be made by qualified professionals.

IMPORTANT NOTE: The propulsion wheels are positioned in the center of the chair, so in the axis of the user's body. This feature provides intuitive mobility in space. This often allows patients with cognitive loss to mobilize the chair without learning.

 The Evolution chair is not designed to be cleaned with a pressure washer or an industrial washing machine. Such practices can lead to component rust and void warranties. In addition, LPA chairs are not designed for outdoor use.

 The Evolution chair must be used with accessories specifically designed for it by **LPA Medical Inc.** It must be used in accordance with recognized health and safety practices.

INSPECTION BEFORE USE

The chair can be shipped fully assembled or partially assembled. It must be inspected when unpackaged and you must notify your supplier if there is any damage or missing parts/accessories so that the situation is remedied before taking possession.

RISK PREVENTION

Always apply the brakes when the wheelchair is not moving and for any transfer or repositioning maneuver. The same rule applies for an empty chair.

To prevent the patient from slipping out of the chair, the seat tilt must be adjusted to an angle appropriate for their condition.

To avoid injury during transfers, be sure that:

- The brakes are applied.
- The patient's arms are inside the armrests.
- The patient's legs are positioned in the center of the seat.
- There is no pinch point possible.
- During transfers, the tilt should be fully forward according to the initial adjustment (see Adjusting the Tilt-in-Space on Page 14 of the adjustments section).

IMPORTANT NOTE: It is important to observe a user's behavior while moving to ensure that they do not pose a risk to themselves or to others.

These measures are necessary for the safety of both the patient and the caregiver. Using the tray for restraint purposes is prohibited and may result in possible strangulation that could cause death. Only the use of approved and prescribed restraints is acceptable.

Note: Contact us for more information about the installation of positioning straps.

IMPROPER USES

- Manipulating the chair without proper training.
- Wheeling the chair outside of designated areas.
- Using it for a patient without assignment or adjustments made by a professional.
- Making adjustments that require frequent repositioning.
- Transferring a patient without using the tilt function.
- Leaving a patient in an unsafe area or without supervision.
- Using it as a shower chair.
- Exceeding the recommended weight limit.
- Allowing a patient to stand without storing the footrests or without applying the brakes.
- Moving the chair without releasing the brakes.

CLEANING

Follow the selected covering manufacturer's recommendations for cleaning. Check with your supplier that the products you use are compatible.

-  **The chair should not be pressure-washed or placed inside a washing machine. These practices may cause the chair components to rust internally, as well as deteriorate the adjustment components, thus voiding the LPA chair warranty.**

MAINTENANCE

For optimum use of the chair, keep it clean and the components properly adjusted. Vinyl coverings should be cleaned with products recommended by the manufacturer. The exterior metal parts of the chair should be cleaned as needed, using the same solution as for the coverings.

As long as the recommendations for use and cleaning are followed, the Evolution chair does not require any preventive maintenance. Some parts will need to be replaced due to normal wear and tear over years of use.

OPERATING FUNCTIONS

The main components for the chair's safe use are:

- A. Brake on each of the central wheels.
- B. Gas spring activation lever to tilt the seat.
- C. Gas spring.
- D. Chair control handles.

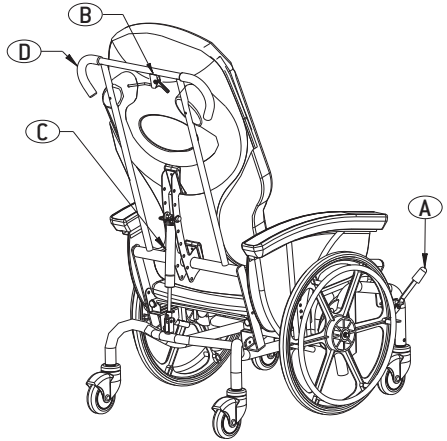

POSSIBLE ADJUSTMENTS

- 1. The seat-to-floor height is adjustable from 16" to 21" (41 to 53 cm) in 1" increments.
- 2. The seat depth is adjustable from 13 ³/₄" to 18" (35 cm to 46 cm).
- 3. The seat/backrest angle is adjustable from 91 to 115 degrees in 8-degree increments.
- 4. The height between the seat and the armrest is adjustable from 6" to 9.75" (15 cm to 25 cm) in ³/₄" (2 cm) increments.
- 5. The seat tilt angle depends on how the chair's other adjustments have been made. You can obtain a helpful lifting angle to make lifting the occupant easier.

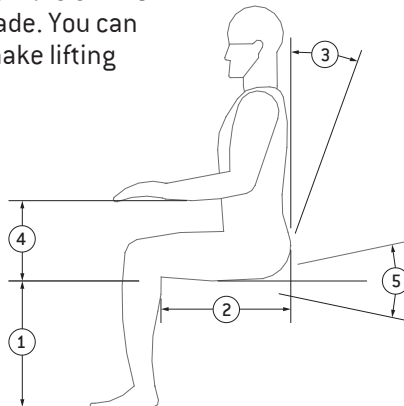

ADJUSTMENT AND OPERATING INSTRUCTIONS

SEAT/FLOOR HEIGHT

1. Determine if the seat needs to be raised or lowered.

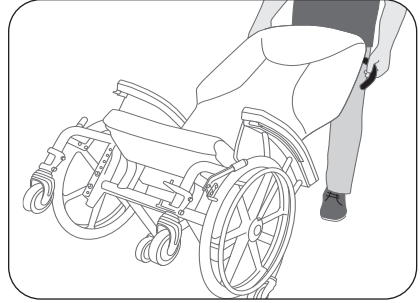

2. Tip the chair backwards until the push bar rests on the floor.

3. Using a $\frac{1}{2}$ " (13 mm) wrench, remove the 4 bolts (2 per side) that hold the seat support.

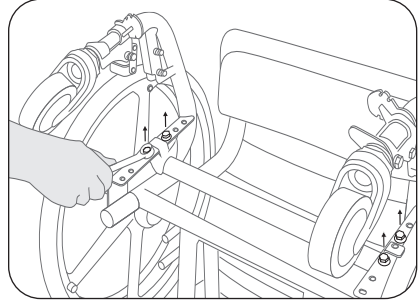

4. Position the seat bracket at the desired height. **MAKE SURE BOTH SIDES ARE AT THE SAME LEVEL.** Put back the 4 bolts without forgetting the flat washers and the lock washers. Tighten properly.

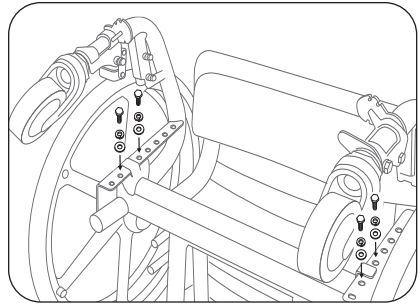

5. Put the chair back on its wheels and have the user try it, to ensure that the feet have sufficient contact with the ground for self-movement. Readjust if needed.

 The height adjustment (from 16" to 21") is done according to the length of the user's lower leg. It is important to have hips, knees and ankles at 90 degrees. The patient's feet must make good contact with the floor.

SEAT DEPTH

! WARNING: THE CHAIR MUST BE UNOCCUPIED WHEN MAKING THIS ADJUSTMENT.

Slide the backrest forward or backward to adjust the seat depth.

1. Determine if the backrest must slide forward or backward to provide the appropriate clearance behind the patient's knees.

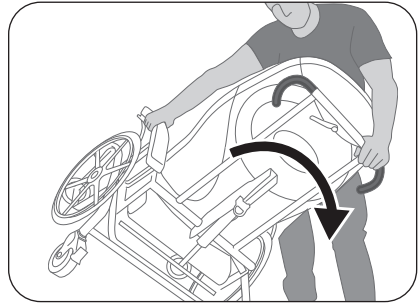

2. Lay the chair on its side.

3. Using a $\frac{1}{2}$ " (13 mm) wrench, loosen the 4 bolts under the seat structure that go through the slots and that control the seat's depth. **WARNING: DO NOT REMOVE THEM ALL THE WAY.**

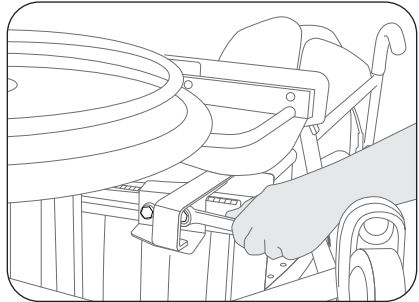

4. Adjust the backrest to the desired position by sliding both sides at the same time so that the backrest moves uniformly.

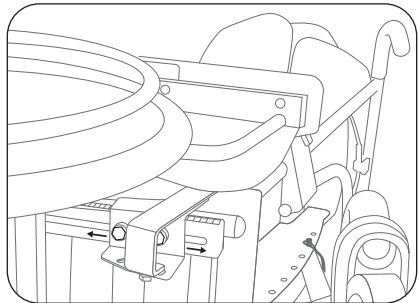

5. When the appropriate depth is reached and equal on both sides, firmly tighten the 4 bolts.

6. Get the user to try it and readjust it if needed.



The seat depth adjustment (from $13 \frac{3}{4}$ " to 18") is done according to the length of the user's leg. It is important that the hollow in the back of the knee (the popliteal fossa) has proper clearance. Adjust the depth of the seat so that your hand easily passes between the knee and the seat cushion. This adjustment will promote good contact with the seat and the back with the backrest.

SEAT/BACKREST ANGLE

⚠ WARNING: THE CHAIR MUST BE UNOCCUPIED WHEN MAKING THIS ADJUSTMENT.

⚠ For this operation, it is highly recommended to lay the chair on its side for easier maneuvering and to reduce the risk of finger jamming.

1. Determine in advance the backrest tilt adjustment required.

2. Apply the brakes, hold the chair on both sides and lay it on its side.

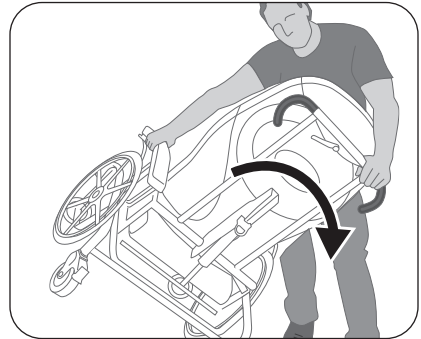

3. Under the seat behind the chair, find the series of 4 holes in an arc pattern that control the backrest angle. Using a 1/2" (13 mm) wrench, remove the bolts on each side.

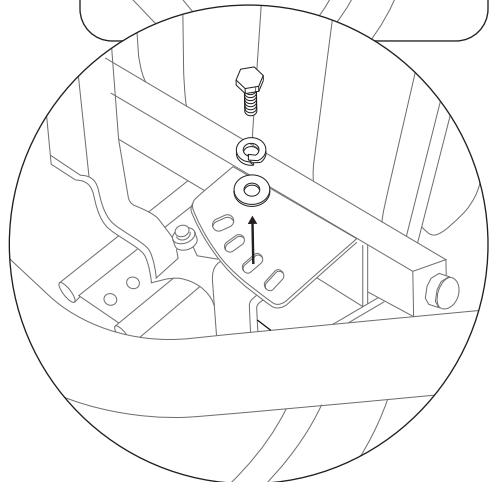
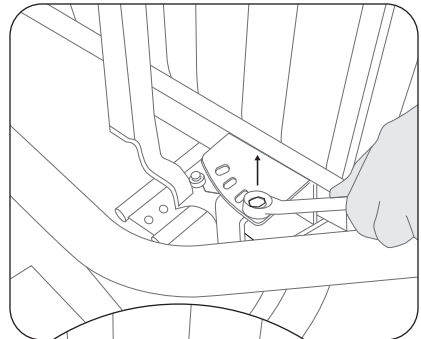

SEAT/BACKREST ANGLE (continued)

4. Push or pull on the top of the backrest to change its angle.

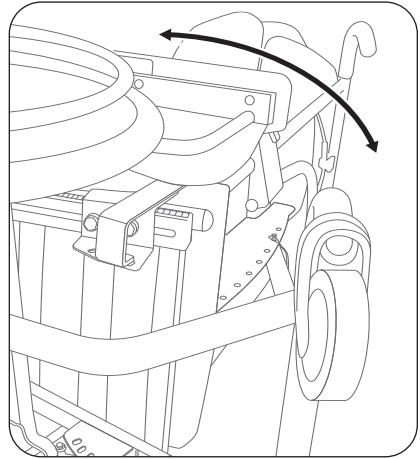

5. Line up the holes and bolt the backrest at the desired angle. Don't forget the lock washers. **BE SURE TO USE THE SAME HOLE ON EACH SIDE.**

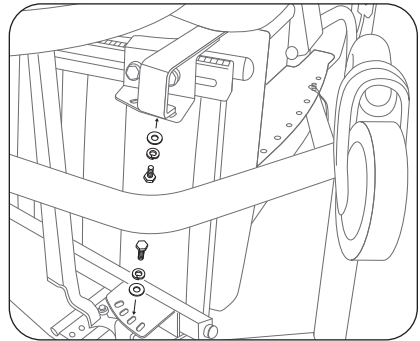

6. Get the user to try it and readjust if needed.



The backrest angle can be adjusted from 91 to 115 degrees to accommodate the shape of the user's back. Adjust the backrest tilt for a comfortable position supporting the lower back and head and to provide the patient with a clear field of vision in front of them. This posture will allow for periods of rest in the chair.

TILT-IN-SPACE

The seat's tilt can be adjusted depending on the user's needs. By varying the position of the gas cylinder on the multi-hole bracket, you can obtain:

- A. Significant assistance standing up.
- B. Slight assistance standing up.
- C. A backward tilt.

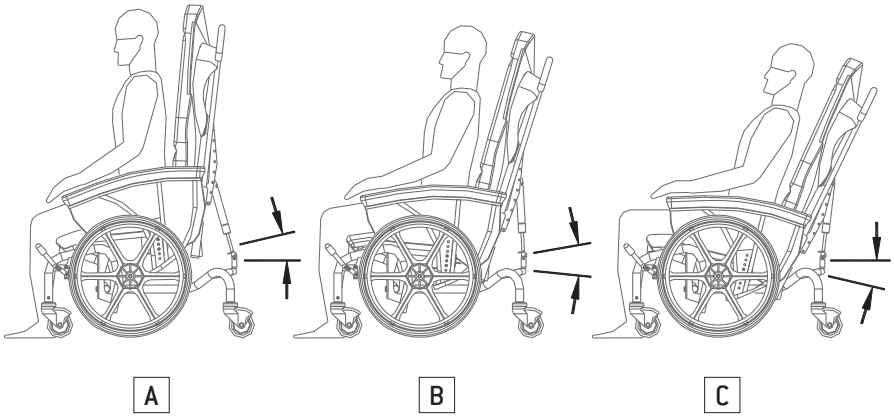

⚠ WARNING: THE CHAIR MUST BE UNOCCUPIED WHEN MAKING THIS ADJUSTMENT.

⚠ For this operation, it is strongly recommended to lay the chair on its side for safer maneuvering to minimize the risk of jamming fingers. It will make the operation easier.

TILT-IN-SPACE (continued)

1. Determine in advance the backrest tilt adjustment required.

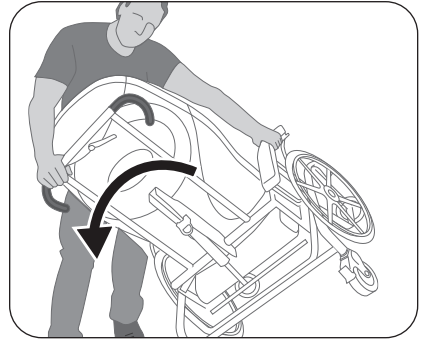

2. Apply the brakes, hold the chair on both sides and lay it on its side.

3. Remove the locking pin from the multi-hole bracket behind the backrest.

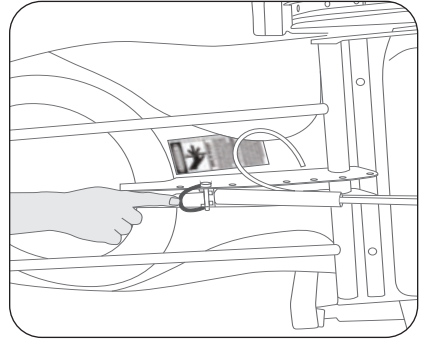

4. Reposition the gas spring in the correct place, then reinsert the locking pin and secure it with the wire snap.

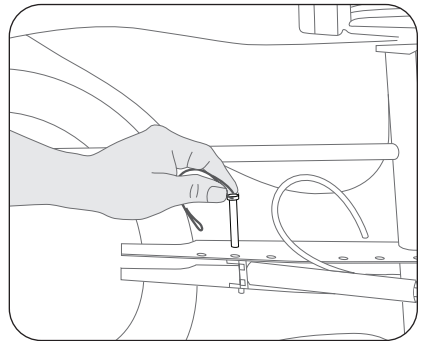

TILT-IN-SPACE (continued)

5. Place the chair upright, then check the tilt's full travel by activating the gas spring and letting the seat raise completely. Then, activate the gas spring and lower the seat completely by applying your weight on the push bar. Ensure that the control cable remains free at all times and isn't pinched anywhere.

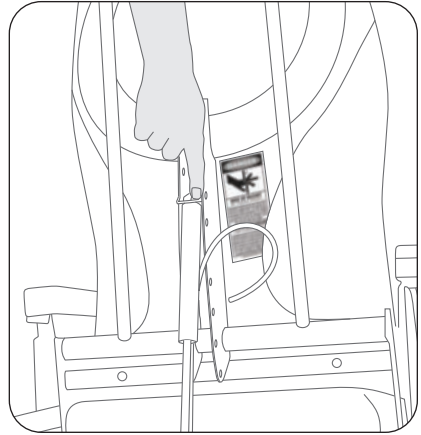

6. Get the user to try it and readjust if needed.



The chair is equipped with tilt-in-space that can be adjusted to any angle from 0 to 23 degrees by using the multi-hole bracket behind the chair's backrest. The caregiver activates the tilt by using the lever located on the right side of the push bar. It is recommended to tilt the chair forward to facilitate transfers while the patient is sitting/standing and for a more upright posture while eating. Tilting the chair backwards is recommended to change the patient's position every 30 minutes to maintain skin integrity and increase postural control (resting position).

ARMREST HEIGHT

1. Use a $\frac{1}{2}$ " (13mm) wrench to remove the bolt securing the armrest on each side of the seat.

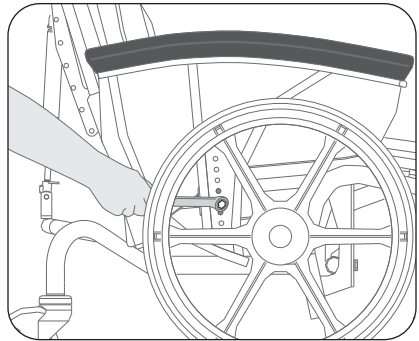

2. Position the armrest at the desired height and replace the bolt, without forgetting the flat washer and the lock washer.

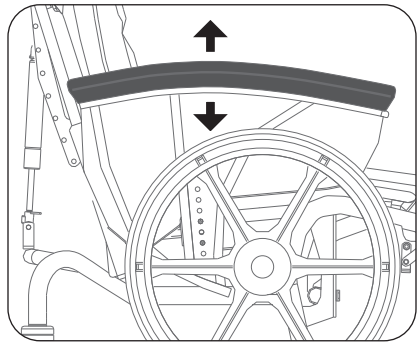

3. Adjust both sides the same way.



Adjust the armrest height from 6" to 9 $\frac{3}{4}$ " depending on the length of the user's arm. Adjust the armrest height so that the user's forearms are supported (elbows at 90 degrees) to relax their shoulders.

LATERAL SUPPORTS – OPTIONAL

Height adjustment

1. Determine the height required for the lateral supports.
2. Using a 7/16" (11 mm) wrench, loosen the 4 nuts slightly from the trunk support attachment, without removing them completely.
Note: hold the assembly with your free hand so that it doesn't fall suddenly.

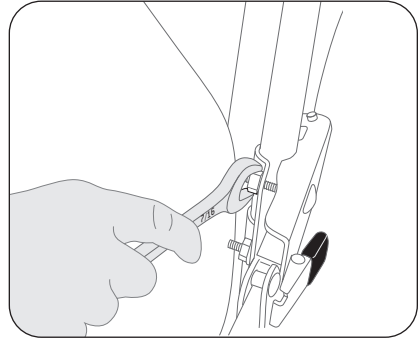

3. Position the lateral supports at the desired height. Retighten the nuts.

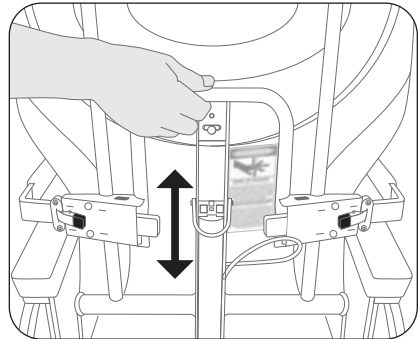

4. Get the user to try it and readjust, if needed.



Use the brackets behind the backrest to adjust the trunk support height so that they are positioned under the user's armpits. It is important to allow a space of three fingers under the armpits to prevent blocking blood circulation under the user's arm.

LATERAL SUPPORTS – OPTIONAL (continued)

Width adjustment

1. Determine if the lateral supports must be widened.
2. Using a 1/8" Allen key, loosen the adjustable lock's two screws without removing them completely so that you can adjust the width.

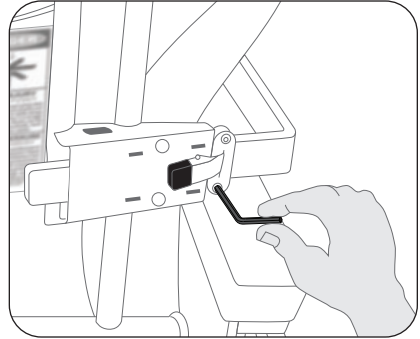

3. Adjust the lateral supports to the desired position.

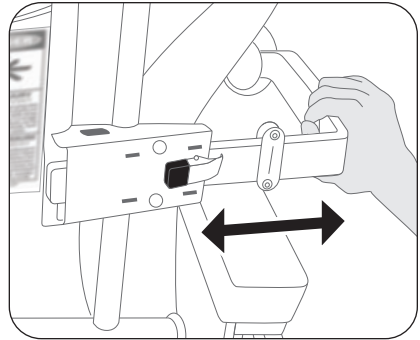

4. Re-tighten the screws. Repeat the procedure on the opposite support.
5. Get the user to try it and readjust if needed.

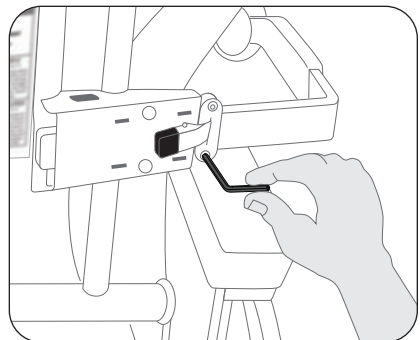

 Adjust the lateral support width using the locks on the lateral support pads behind the backrest so that you can slide the thickness of a hand easily between the user's trunk and the pad on each side. These adjustments will ensure that the user's trunk posture is better aligned against the backrest.

USING THE FOOTRESTS – OPTIONAL



Footrests are optional on the Evolution chair. It is recommended to use them when the chair is pushed by others to prevent injury to the lower limbs.

1. Press on the black lever on the footrest assembly and swivel the assembly 180 degrees outward, until the footrest locks into place (you will hear a click).

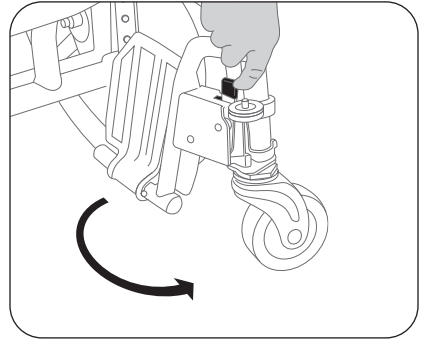

2. Lower the footrest.

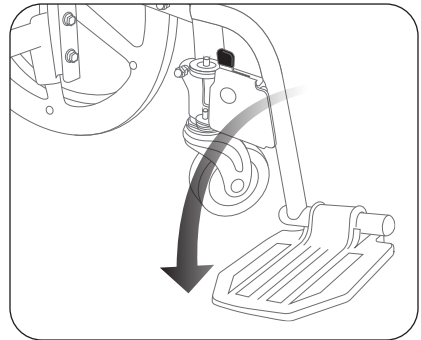

3. Repeat the operation on the other side.

4. To store the footrest, raise the footrest upward, activate the black lever and pivot the footrest inward until it locks into place.

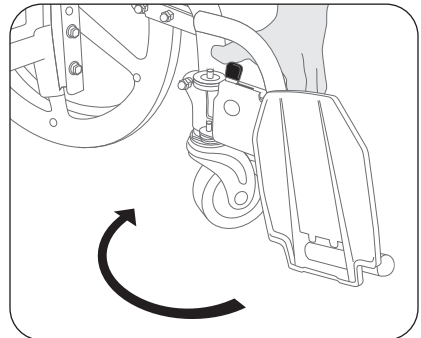

SERIAL NUMBER LOCATION

Each **LPA Medical Inc.** chair is identified by a serial number. To order replacement parts, always provide your LPA chair's serial number.

The serial number is located on a label affixed to the cross-tube behind the base.

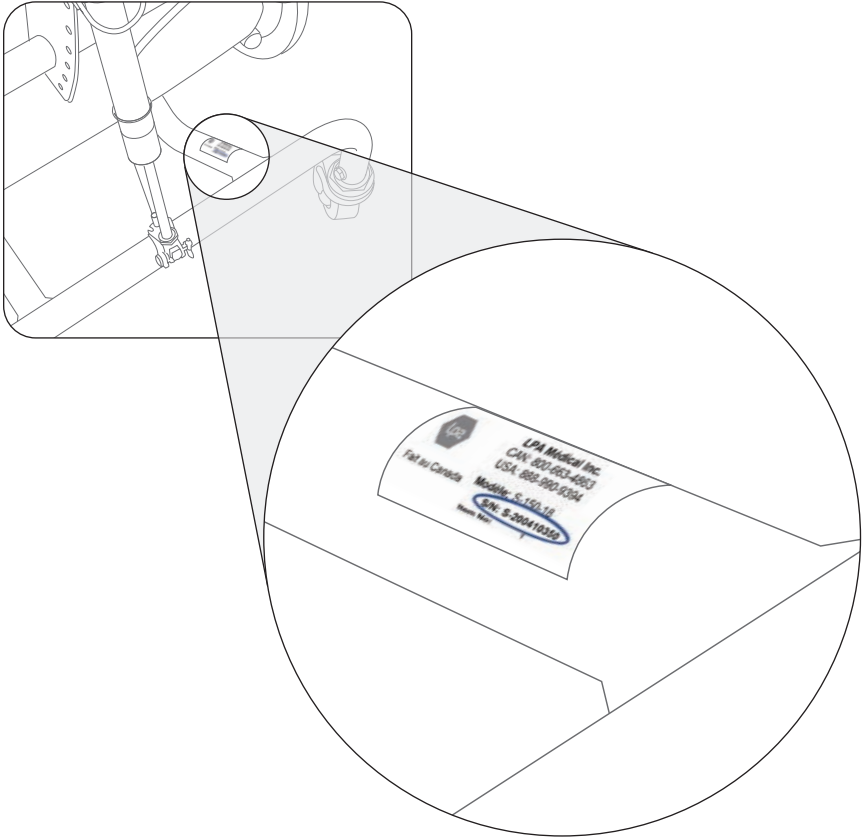

OPTIONS AND ACCESSORIES

Code	Description
SA-15	Removable and interior-folding footrests
SA-20	Retractable and adjustable thoracic support assemblies
SA-40-*	Removable activity table
SA-40-**.2	Activity table with Lexan window
SA-50	Cervical support
SA-60	PRE-CURE PRO cushion
SA-70	Heel support loops
SA-80	Seat depth adjustment 15 1/2" to 20 1/4"
SA-85	Tool-less depth adjustment
SA-130	Adjustable elevating leg rest (sold individually or in pairs)
SA-215-*	Adjustable tension backrest
SA-220-*‡	Full-width footrest (requires option SA-15)
SA-275	IV pole with rear attachment (right side only)
SU-07	Black vinyl padded armrest
AB-08H	Contoured headrest with universal attachment harness
AC-04	Leatherette padded tray cover
AE-02	Universal drainage bag holder
RA-03	Lateral table straps (not a restraining device)
RA-03A	Wrap around table strap (not a restraining device)
RA-19	Perineal abductor and seat cover
RA-20	Backrest canvas for lateral trunk supports (supports not included)
RA-23	10 cm (4") lateral trunk supports with backrest canvas
RA-24	15 cm (6") lateral trunk supports with backrest canvas

* Always specify the color, width, fabric pattern and serial number of the Evolution chair when ordering replacement parts. See page 21 for the location of the serial number. Replacement parts may have slight color differences from those of the original chair. LPA Medical cannot be held responsible for these differences.

‡ Not available for chairs 16" wide.

ADDITIONAL ERGONOMIC RECOMMENDATIONS



CERVICAL SUPPORT

A cervical support is optional on the Evolution chair. It can be used to increase comfort by allowing the head to rest on the back of the chair in a tilted position. The cervical support should be positioned at the base of the head and neck in order to fill the space according to the user's comfort.



POSITIONING STRAP

The positioning strap is optional on the Evolution chair. It is recommended to use it in order to maintain a good pelvic posture while benefiting from chair's postural equipment. It is also recommended to stabilize the pelvis in order to have effective propulsion with the hands and feet. The positioning strap must be well-fitting, so that a hand with the palm open can pass between the strap and the user's body. Never use positioning straps as a means of restraining the user. Improper use can result in serious injury or even death.



FOOTRESTS

Using footrests is optional on the Evolution chair. However, it is recommended to use them when the chair is being pushed by another person to prevent injuring the patient's lower limbs.



GETTING UP

To get up from the Evolution chair more easily (always do so in the presence of another person who has received training):

- Apply the brakes on the chair's 2 central wheels (performed by the user or a caregiver).
- Raise the tilt of the chair to a straighter position in preparation for transfer (performed by a caregiver).
- Store the footrest inward if applicable (performed by a caregiver).
- Slide the buttocks to the center of the chair.
- Place the feet under the seat.
- Lean on the armrests with your hands.
- Lean forward while looking straight ahead.
- Get up by pushing on your feet and hands, then straighten up.

SITTING DOWN

To sit in the Evolution chair safely (always do so in the presence of another person who has received training):

- Apply the brakes on the chair's two central wheels (performed by the user or a caregiver).
- Raise the tilt of the chair to an upright position to prepare for the transfer (performed by a caregiver).
- Stand in front of the chair and step backwards until the back of the knees touch the seat.
- Lean forward and bend your knees while placing your hands on the armrests while sitting on the seat.
- Slide the buttocks backwards and lower slowly while continuing to lean forward.
- Slide the buttocks into the back of the chair.

MOVING USING THE HANDS AND FEET

It is possible to move with the Evolution chair with your hands and feet by adjusting the chair's floor-to-seat height according to the length of the user's forearm. To propel the chair effectively using the hands and feet, it is recommended to use both wheels' hand rims while pushing forward using your heels.

OPTIONS AND ACCESSORIES

There are a multitude of options and accessories available to personalize your Evolution chair and optimize your comfort according to your specific needs and/or if your condition changes. Feel free to ask any questions to optimize your chair's fit.

TERMS & CONDITIONS

APPLICABLE TO PRODUCTS PURCHASED AS OF SEPTEMBER 1, 2018

GENERAL

LPA Medical inc. reserves the right to modify without notice or obligation the design, specifications and prices of the equipment it manufactures. Shipping is charged at the current price at the time of delivery.

The minimum order requirement is \$25.

DAMAGE DURING TRANSPORTATION

All goods damaged by transport must be immediately reported upon delivery, followed by a written claim within five (5) days. A copy of the claim must be sent to LPA. Any unreported damage during this period will void the **LPA Medical Inc.** warranty.

Additional costs of handling and/or using a platform when unloading may apply and are at the customer's expense.

RETURNS

Merchandise to be returned must have prior written authorization from our Customer Service Department. All return requests must contain the following information:

- The reason(s) for the return.
- The LPA invoice number or delivery slip.
- The LPA model or part number.
- The number of items being returned.

Unauthorized returns will not be accepted. All authorized returns must be shipped pre-paid except where there has been an error in processing or a defect in materials or workmanship. In this case, contact **LPA Medical Inc.** for special instructions.

GENERAL WARRANTY

The **LPA Medical Inc.** warranty covers manufacturing defects for the original owner/user, except for the exclusions below, for the periods below from the date of purchase:

Useful life* for the metal structure of the chairs.

5 years on the wooden structures of self-locking rocking chairs **Thera-Glide® models W and T.**

3 years for the backrest mechanism of **Thera-Glide®** self-locking rocking chairs.

3 years on the padding of the chairs.

2 years for all other mechanisms, gas or mechanical locking cylinders, control cables, wheels, table trays.

1 year on all accessories purchased separately from chairs and replacement parts.

If a part is missing, contact our customer service with the following information:

1. Model, serial # and part #.
2. Purchase date and invoice number.
3. Description of the problem.

* The useful lifespan of an LPA chair is estimated to be 10 years.

OUR COMMITMENT

LPA Medical inc. agrees to provide replacement parts for a period of 10 years after the date of purchase of the product. **LPA Medical Inc.** reserves the right to provide replacement parts with a different design than that of the replaced part, at its sole discretion.

LPA Medical Inc.'s obligation is expressly limited to correcting the defect by adjusting, repairing or replacing the equipment, at LPA's sole discretion.

EXCLUSIONS

- Normal wear and tear.
- Water or fire damage, including damage from pressure washers and automatic wheelchair washers.
- Rust and damaged covering.
- Unauthorized repair or modification or done with parts other than the original ones.
- Damage resulting from abnormal or abusive use.
- Damage caused by exposure to weather.

PARTS LIST

N°	Code	Description
1	SP-210-xx*	Base assembly
2	SP-220-xx*	Pivot assembly
3	SP-230-xx*	Seat assembly
4	SP-240	RIGHT armrest assembly
5	SP-241	LEFT armrest assembly
6	SP-050-xx*	Backrest assembly
7	SP-070	Trunk support – support assembly
8	SP-072	Trunk supports
9	SP-073	Trunk support replacement cushion
10	SP-074	Trunk support adjustment plate
11	SP-095	Evolution central wheel brakes (2)
12	SP-096	Evolution central wheel suspension kit
13	SP-290L/R/P	Footrest clamp (L = left, R = right, P = pair)
14	SP-292R	Right footrest assembly
15	SP-292L	Left footrest assembly
16	SP-328 ou SP-355R (S-250-22 & 24)	Right backrest adjustment plate
17	SP-329 ou SP-355L (S-250-22 & 24)	Left backrest adjustment plate
18	SA-15	Removable and retractable footrests
19	SA-20	Retractable and adjustable thoracic support assemblies
20	SA-40-xx*	Removable activity tray
21	SA-50	Cervical support
22	SA-70	Heel support loops
23	SA-75	IV pole with rear attachment (right side only)
24	SA-85	Tool-less depth adjustment
25	SA-220-xx* **	Full-width footrest (requires option SA-15)
26	SA-130L/R/P	Elevating leg rest with lift assistance (L = left, R = right, P = pair)
27	SA-215-xx* **	Adjustable tension backrest
28	SU-01-xx* **	Backrest cushion
29	SU-02P-xx* **	Pressure distribution seat cushion
30	SU-06**	Lateral armrest cushion (pair)
31	SU-04 ou AL40306 (S-250-16)	Black plastic backrest shell, except for S-250-16: painted aluminum plate
32	SU-05	Black polyurethane armrest, right or left
33	SW-03	4" (10 cm) swivel wheel
34	SW-04	Central wheel with hand rim (19 1/4" – 49 cm exterior diameter)
35	CYL-S01 ou CYL-S02 (S-250-22 et 24)	Gas spring
36	QCL50005	Gas spring activation handle with cable
37	XPE65052L	Guide end for table slide, left side
38	XPE65052R	Guide end for table slide, right side

* Replace "xx" in the part n° with the chair's width (16", 18", 20", 22" or 24"). For cushions, use 18" for a 20" chair and 24" for a 22" chair.

** Always specify the color, width, fabric pattern and serial number of your Evolution chair when ordering replacement parts. See page 21 for the location of the serial number. Replacement parts may have slight color differences from those of the original chair. LPA Medical cannot be held responsible for these differences.

VUE ÉCLATÉE

EXPLODED VIEW

